

# DDS *PLUS* CONCRETE SCREW

Heraklith® | DDS *plus* concrete screws are specifically suited for mounting wood wool panels directly to normal concrete (2000-2600 kg/m³). Comprehensive international fire testing has shown that combining DDS *plus* screws with the Heraklith® Tektalan A2 or the A2 Decorative panel results in excellent performance in fire-resistant applications.

## STANDARD VERSION

The concrete screw consists of steel with a corrosion class C3. The screw can therefore be used in an outdoor environment that is not directly exposed to the elements. The screws come standard in the colours white and nature tone (RAL 1015).



## ADVANTAGES

- ✓ Plastic screw head with wood fibre structure for decorative finish
- ✓ Simple installation: pre-drill and screw in
- ✓ Minimal anchorage depth
- ✓ Can be used for fire-resistant applications
- ✓ Available in various RAL colours upon request

## SPECIFICATIONS

Art. No. Nature tone	Art. No. White	Screw length (mm)	Panel thickness to (mm)	Units / pack
416 810	596 858	50	25	100
416 812	416 798	75	35/50	100
416 813	416 802	85	60	100
416 814	416 803	100	75	100
596 896	596 895	110	85	100
416 815	416 804	125	100	100
416 816	416 805	150	125	100
416 817	416 806	175	150	100
416 818	416 807	200	175	100
416 819	416 808	225	200	100
416 820	416 809	250	225	100

Different colours upon request



Always process our Heraklith wood wool panels according to our processing instructions. These can be found on [heraklith.com/downloads](http://heraklith.com/downloads)

## TECHNICAL INFORMATION

Corrosion category	C3
Tensile strength concrete C20/25	0.5 kN
Screw diameter	7.5 mm
Head diameter	26 mm
Drilled hole diameter	6 mm
Drilled hole depth	30 mm
Anchoring depth in concrete	25 mm
Screw drive	Torx T30
Recommended anchoring material	Concrete (2000–2600 kg/m <sup>3</sup> )

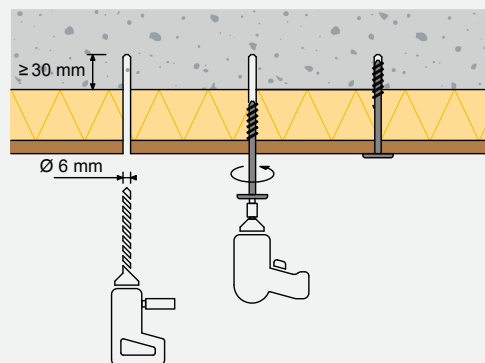

**Do you want more information? Please contact us**

### **Knauf Insulation B.V.**

Dakota 7  
5126 RL Gilze

Tel: + 31 (0)162 - 42 12 45

e-mail: [woodwool.export@knaufinsulation.com](mailto:woodwool.export@knaufinsulation.com)

[www.heraklith.com](http://www.heraklith.com)

Our general sales and delivery conditions apply to all our offers, communications and agreements, notwithstanding any provision to the contrary that can be found on our order forms or elsewhere. An overview of our general terms and conditions can be found on: [heraklith.com/downloads](http://heraklith.com/downloads). Extreme caution was observed when putting together and processing the information, texts and illustrations in this document. Nevertheless, errors cannot quite be ruled out. The publisher and editors cannot assume legal responsibility or any liability whatever for incorrect information and the consequences thereof.

V2-UK 03/2023

Heraklith<sup>®</sup> is a registered  
trademark of

**KNAUFINSULATION**